

# HOMELIFT TECHNICAL SPECIFICATIONS

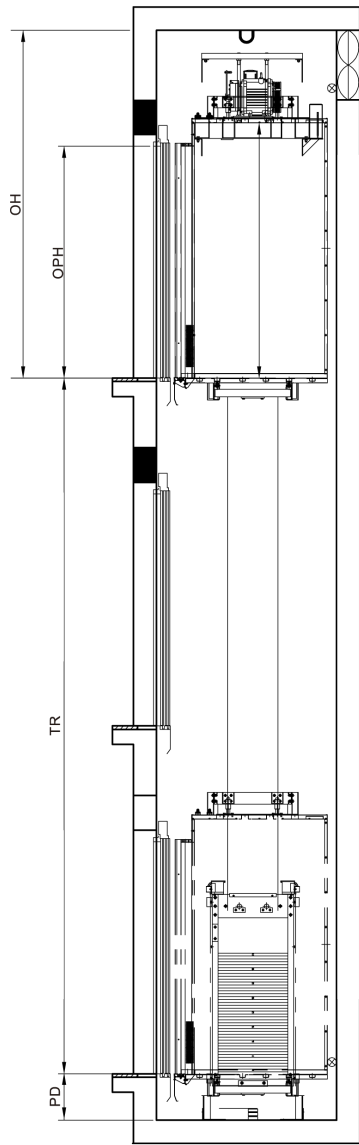

HOISTWAY ELEVATION

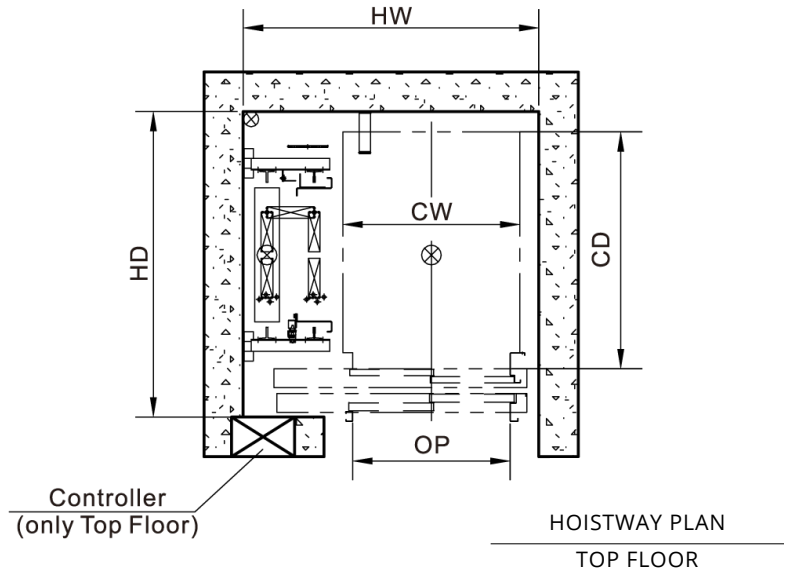

HOISTWAY PLAN  
TOP FLOOR

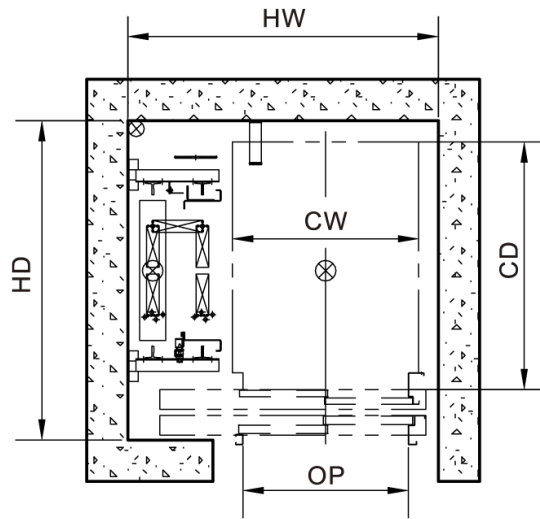

HOISTWAY PLAN  
OTHER FLOOR

CAPACITY		CAR			DOOR		SHAFT		THROUGH OPENING
Load	Person	Type	Width	Depth	Type	Opening	Width	Depth	
kg	P	CT	CW	CD	DT	DO	HW	HD	
320	4P	Deep	900	1200	2SO	800	1500	1500	1700
					2CO	700	1700	1450	1550
					2CO	800	1800	1450	
400/450	6P	Deep	1000	1200/1250	2SO	900	1600	1600	1700/1750
		Wide	1000	1100	2CO	800	1800	1350	N/A
			1100	1100	2CO	900	1950	1350	

*Max Travel: Less than 18m*

Speed	Capacity	Overhead	Pit	Car Clear Height	Door Height
m/s	kg	mm	mm	mm	mm
0.4 / 0.5	320	2750	380	2200	2100
0.4 / 0.5	400				
0.4	450				